

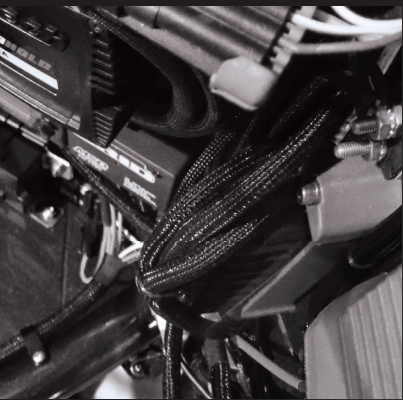

# *FuelTech*



## *ALCOHOL-O<sub>2</sub>*

High Precision Wideband O<sub>2</sub> Sensor Conditioner  
Condicionador de Sonda de Banda Ancha de Alta Precisión

**Installation and Operation Guide**  
**Manual de Instalación y Especificaciones Técnicas**



## Index

1. Presentation.....	2
2. Characteristics.....	2
3. Warranty.....	3
4. Wideband O2 sensor .....	5
4.1 NTK sensor.....	5
4.2 Bosch LSU 4.2 sensor .....	5
4.3 O2 sensor installation .....	5
5. Alcohol O2 installation and calibration.....	6
5.1 Harness connection.....	6
5.2 Harness wiring.....	7
5.3 Free-air calibration .....	7
5.4 Analog output Lambda/AFR x Voltage table.....	9

**EN**

## 1. Presentation

The FuelTech Alcohol O2 module is a highly precise tool used for monitoring and tuning internal combustion engines that run extremely low AFRs, mainly in Drag Race applications.

The main differences in relation to WB-O2 Slim are the number of channels, the sensor type and the reading scale, which is capable of reading from 1.80 AFR Alcohol up to infinity.

This module also has analog outputs of the O2 readings to send to FT500/FT500LITE or FT600.

EN

## 2. Characteristics

- Dual channel sensor input
- AFR or lambda reading (from 1.80 AFR Alcohol up to free air)
- 0-5V analog outputs (same as the reading scale)
- Free air calibration (when using POWER FT LINE)
- CAN communication with POWER FT LINE

### Dimensions:

- 4.5in x 3.5in x 1.8in

### 3. Warranty

**The use of this equipment implies the total accordance with the terms described in this manual and exempts the manufacturer from any responsibility regarding to product misuse.**

Read all the information in this manual before starting the product installation.

**This product must be installed and tuned by specialized auto shops and/or personnel with experience on engine tuning.**

Before starting any electric installation, disconnect the battery.

The inobservance of any of the warnings or precautions described in this manual might cause engine damage and lead to the invalidation of this product warranty. The improper adjustment of the product might cause engine damage.

This product does not have a certification for the use on aircrafts or any flying devices, as it has not been designed for such use purpose.

In some countries where an annual inspection of vehicles is enforced, no modification in the OEM ECU is permitted. Be informed about local laws and regulations prior to the product installation.



*Important warnings for proper installation of this product:*

*Always cut the unused parts of cables off – NEVER roll up the excess*

*The black wire of the harness **MUST** be connected directly to the **battery's negative terminal**, as well as each one of the sensors' ground wires.*

*To prevent possible damage to the module install the 4 mounts that come with the product.*

#### Limited Warranty

All products manufactured by FUELTECH are warranted to be free from defects in material and workmanship for one year following the date of original purchase. Warranty claim must be made by original owner with proof of purchase from authorized reseller. This warranty does not include sensors or other products that FUELTECH carries but did not manufacture. If a product is found defective, such products will, at

FUELTECH's option, be replaced or repaired at cost to FUELTECH. All products alleged by Purchaser to be defective must be returned to FUELTECH, postage prepaid, within one year warranty period.

This limited warranty does not cover labor or other costs or expenses incidental

to the repair and/or replacement of products or parts. This limited warranty does not apply to any product which has been subject to misuse, mishandling, misapplication, neglect (including but not limited to improper maintenance), accident, improper installation, tampered seal, modification (including but not limited to use of unauthorized parts or attachments), or adjustment or repair performed by anyone other than FUELTECH.

The parties hereto expressly agree that the purchaser's sole and exclusive remedy against FUELTECH shall be for the repair or replacement of the defective product as provided in this limited warranty. This exclusive remedy shall not be deemed to have failed of its essential purpose so long as FUELTECH is willing and able to repair or replace defective goods.

FUELTECH reserves the right to request additional information such as, but not limited to, tune up and log files in order to evaluate a claim.

**Seal violation voids warranty and renders loss of access to upgrade releases.**

Manual version 1.4 – May/2018

## 4. Wideband O2 sensor

### 4.1 NTK sensor

The Alcohol O2 was developed to use a NTK wideband O2 sensor that is used in engine laboratories, because of its extreme accuracy and speed in reading at different AFRs. To purchase the NTK sensor, contact FuelTech.



EN

### 4.2 Bosch LSU 4.2 sensor

As a lower cost alternative, you can use the same Bosch LSU 4.2 sensor used in WB-O2-Meter Slim, with Bosch part number 17014, 0258007057 or 0258007351 and VW 021-906-262-B.



### 4.3 O2 sensor installation

The sensor must be inserted in the exhaust system in an angle between 10 to 80 degrees to horizontal position, that is, with its end downward, in such a way that steam droplets cannot be accumulated between the body of the sensor and its ceramic part, which could damage the sensor.

When installing the sensor after the turbo, it must have its tip exposed to the exhaust gas flow. When placing it before the turbo, on the exhaust manifold, its tip must stay hidden from direct exhaust gas flow.

The sensor must stay away from the cylinder head and from areas where one cylinder might affect the exhaust air more than the others. Avoid placing the

sensor close to the exhaust manifold joints, as some allow the inflow of air, resulting in incorrect readings.

The sensor must never be installed in the exhaust in the 6 and 12 o'clock position. The correct is to install the sensor in the 2, 3, 9 or 10 o'clock positions.

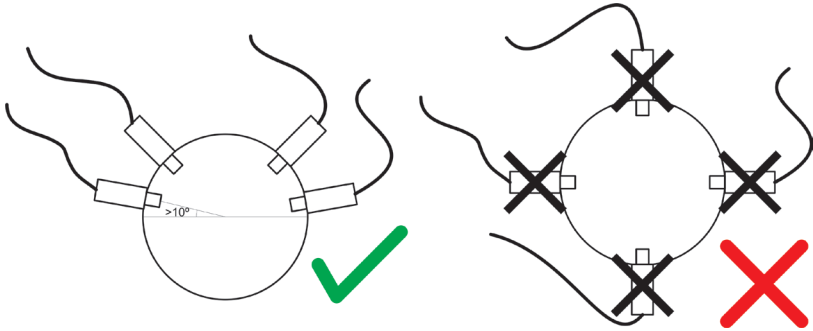

EN

## 5. Alcohol O2 installation and calibration

The Alcohol O2 has a sealed AMP connector, where you will find all the wires of sensors, feed, analog outputs and CAN.

See the following wiring diagram for details on the connections

### 5.1 Harness connection

Wire color	Pin	Function	Information
Blue	3	O2 #2 (right)	H+ O2 #2 (right)
Yellow	4	O2 #2 (right)	H- O2 #2 (right)
White	5	O2 #2 (right)	IP+ O2 #2 (right)
Black/White	8 and 9	Power ground input	<b>Engine ground (head/block). Connect to chassis or engine head/block. Do not connect it to the battery negative.</b>
Gray	10	O2 #2 (right)	VS+ O2 #2 (right)
Brown	11	O2 #2 (right)	VS- O2 #2 (right)
Yellow/Red	12	O2 #2 (right) analog output	0-5V analog output O2 #2 (right)
White/Red	13	CAN FT	CAN HI
Black	14 and 15	Battery's negative input	Connected <b>directly</b> to the battery. <b>Do not connect this wire to the chassis, engine block or head.</b>



Wire color	Pin	Function	Information
Gray	16	O2 #1 (left)	VS+ O2 #1 (left)
Brown	17	O2 #1 (left)	VS- O2 #1 (left)
Yellow/Red	18	O2 #1 (left) analog output	0-5V analog output O2 #2 (left)
Yellow/Blue	19	CAN FT	CAN LO
Red	20	12V input from relay	Connect to pin 87 of Main relay. 15A fuse is recommended
Blue	22	O2 #1 (left)	H+ O2 #1 (left)
Yellow	23	O2 #1 (left)	H- O2 #1 (left)
White	24	O2 #1 (left)	IP+ O2 #1 (left)



### 5.2 Harness wiring

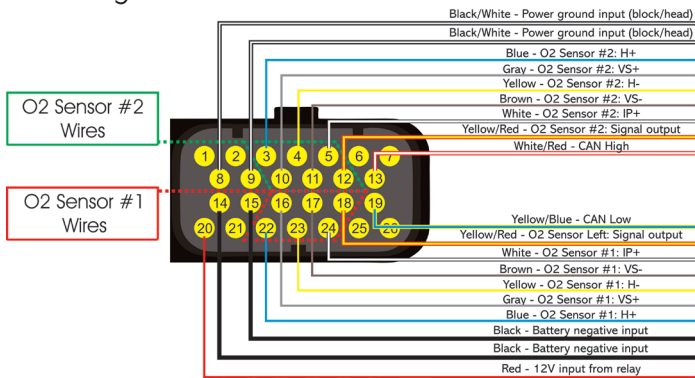

### 5.3 Free-air calibration

To use the Alcohol O2 the free-air calibration of the sensors is mandatory. To perform this calibration, remove the sensor from the exhaust and let it ventilate for 10 minutes, power on the Alcohol O2 and the Power FT line.

After the sensors are heated wait at least 3 more minutes then go through the interface: Main Menu / Sensors and Calibration / O2 sensor (1 or 2) / Alcohol O2 and press calibrate.

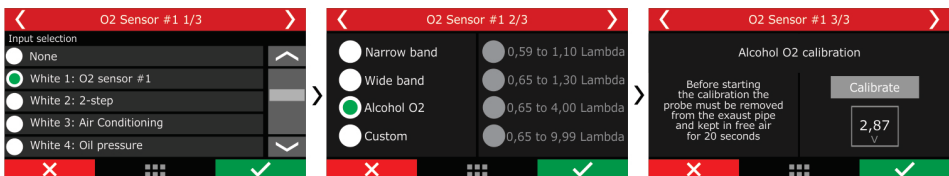

The free-air calibration also can be performed through FTManager Software. To reach the calibration screen, with an open map, go to Sensors and Calibration in the left menu, then enter Inputs and select the channels where the Alcohol O2 analog outputs are connected.

With the sensors out of the exhaust, turn the Alcohol O2 on and wait them to heat for at least 3 minutes. After that, enable the calibration.

This procedure must be done on both channels. With everything done, confirm changes, save the map and write ECU.



Below is the screen where the calibration is done:

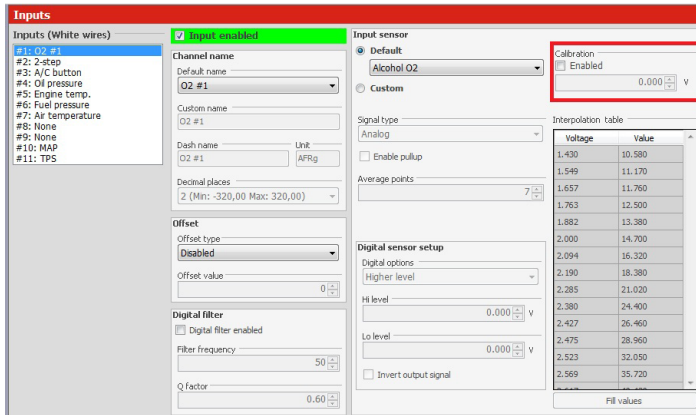

For NTK sensors, free air voltage is around 3.000V. For Bosch sensors, free air voltage is around 2,700V.

While the sensors are heating, analog output voltage is 5.000V.

Voltage differences higher than 0.100V when heating may indicate a wrong calibration, a damaged sensor or a wiring problem, especially on the negative (black wire) and/or power ground (black/white wire).

## 5.4 Analog output Lambda/AFR x Voltage table

Voltage (V)	AFR (Gasoline)	AFR (Alcohol)	Lambda
0.048	4.120	1.800	0,280
0.521	6.470	2.820	0,440
0.765	7.640	3.340	0,520
1.003	8.530	3.720	0,580
1.145	9.260	4.040	0,630
1.287	10.000	4.370	0,680
1.430	10.580	4.620	0,720
1.549	11.170	4.880	0,760
1.657	11.760	5.140	0,800
1.763	12.500	5.460	0,850
1.882	13.380	5.840	0,910
2.000	14.700	6.420	1,000
2.094	16.320	7.130	1,110
2.190	18.380	8.030	1,250
2.285	21.020	9.180	1,430
2.380	24.400	10.660	1,660
2.427	26.460	11.560	1,800
2.475	28.960	12.650	1,970
2.523	32.050	14.000	2,180
2.569	35.720	15.600	2,430
2.617	40.430	17.660	2,750
2.665	46.310	20.220	3,150
2.711	53.950	23.560	3,670
2.736	59.240	25.870	4,030
2.760	65.420	28.570	4,450
2.783	72.770	31.780	4,950
2.808	82.320	35.950	5,600
2.854	110.250	48.150	7,500
2.902	167.870	73.320	11,420
2.973	343.250	149.910	23,350
3.006	470.400	205.440	32,000

EN



## Indice

1.	Presentación .....	2
2.	Características .....	2
3.	Término de Garantía .....	3
4.	Sensor Lambda de Banda Larga.....	4
	4.1 Sonda NTK .....	4
	4.2 Sonda Bosch LSU 4.2 .....	4
	4.3 Instalación da Sonda Lambda.....	4
5.	Instalación Eléctrica.....	5
	5.1 Conexiones del arnés eléctrico .....	5
	5.2 Esquema de conexión del conector eléctrico.....	6
	5.3 Calibración al aire libre (free-air) .....	6
	5.4 Tabla de lambda/AFR x voltaje de la salida analógica .....	8

ES

## 1. Presentación

La FuelTech Alcohol O2 es una herramienta utilizada para el monitoreo y acierto de motores a combustión para fajas de lambda extremadamente ricas, con aplicación recomendada para vehículos de arrancadas.

Las mayores diferencias en relación a WB-O2 Slim son con relación al número de canales, al tipo de sonda de banda larga utilizada y la faja de lectura, capaz de leer hasta 0,26  $\lambda$

O equipamiento cuenta aun con salidas analógicas para enviar a la FT500 y FT600 o para un datalogger, como la FuelTech WB-O2 Datalogger o PRO24Datalogger.

ES

## 2. Características

- Entrada para dos sondas
- Lecturas en lambda o AFR en la faja de 0,28  $\lambda$  hasta infinito;
- Salidas analógicas 0-5V (en la misma faja de lectura);
- Calibración al aire libre;
- Comunicación CAN con Linea POWER FT;

### Dimensiones:

- 115mm x 90mm x 45mm

### 3. Término de Garantía

**La utilización de este equipo implica la total concordancia con los términos descritos en este manual y exige al fabricante de cualquier responsabilidad sobre la utilización incorrecta del producto.**

Lea todo el Manual del producto antes de comenzar la instalación.

**Este producto debe ser instalado y regulado por talleres especializados o personas capacitadas.**

Antes de comenzar cualquier instalación eléctrica desconecte la batería.

La desobediencia de cualquiera de uno de estos avisos y precauciones descritos en este manual puede causar daños al motor y la pérdida de la garantía de este producto. Acierito incorrecto del producto puede causar daños al motor. Este equipamiento no posee certificación para la utilización en aeronaves o similares, por lo tanto no es previsto para este fin.

En algunos países que realizan inspección vehicular anual no es permitida cualquier modificación en el sistema de inyección original. Infórmese antes de la instalación.

ES



*Avisos Importantes para la correcta instalación:*

*Siempre corte las sobras de cable – NUNCA enrolle los sobrantes.*

*El cable negro del cableado PRECISA ser conectado directamente al **negativo de la batería**, así como todos los negativos de sensores.*

*Para evitar posibles daños en el módulo instale los 4 cojines que vienen con el producto.*

#### Garantía Limitada

La garantía de este producto es de 1 año a partir de la data de compra y cubre apenas defectos de fabricación, mediante la presentación de la nota fiscal.

Defectos y daños causados por la incorrecta utilización o instalación del producto no son cubiertos por la garantía. Este análisis es hecho por sector de manutención de FuelTech.

**La violación del Lacre implica la pérdida de la garantía del producto.**

Manual versión 1.4 – Mayo/2018

## 4. Sensor Lambda de Banda Larga

### 4.1 Sonda NTK

El Alcohol O2 fue desarrollado para la utilización de una sonda de banda larga NTK para el uso en bancos de motores, buscando extrema precisión y rapidez en las lecturas en diferentes fajas de lambda. Para adquirir la sonda NTK, entre en contacto con FuelTech.



ES

### 4.2 Sonda Bosch LSU 4.2

Como una alternativa de menor costo, es posible utilizar la misma sonda Bosch LSU 4.2 utilizada en la WB-O2 Meter Slim, con part number Bosch O 258 007 057 o O 258 007 351 e VW O21-906-262-B.



### 4.3 Instalación da Sonda Lambda

El sensor debe ser colocado en el sistema de escape en un ángulo entre 10 y 80 grados en relación horizontal, o sea, con la punta para abajo. Eso hace que no se acumulen gotas de vapor de agua entre o cuerpo del sensor y la parte cerámica del mismo, lo que puede ocasionar daños durante el uso del sensor. No debe ser colocado verticalmente, ya que recibe calor en exceso en esa posición.

Cuando es instalado después de la turbina debe tener su punta expuesta al flujo de los gases del escape. Cuando es instalado antes de la turbina, en el colector de escape, su punta debe quedar protegida del flujo directo de gases de escape.



La sonda debe quedar lejos de la tapa de cilindros y de áreas donde un cilindro pueda afectar más el aire de escape de que de lo demás. Evite colocarla próxima a las juntas del escape, ya que algunos modelos permiten la entrada de aire y causan errores en la lectura.

El sensor nunca debe ser instalado en el escape entre 3 y 9 horas. La posición de 12 horas no es la más indicada, mas puede ser utilizada cuando se encuentre lejos de la tapa de cilindros, o sea, más de 2m.

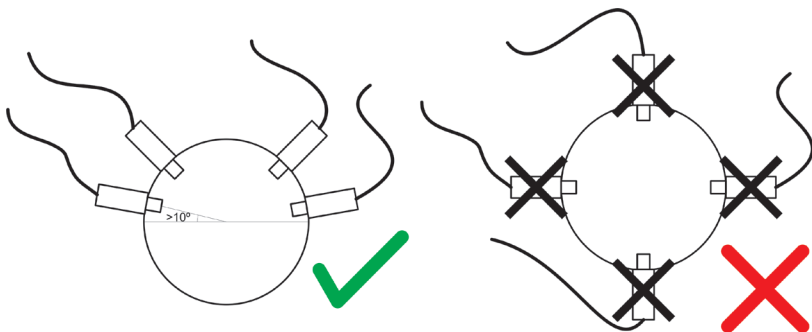

ES

## 5. Instalación Eléctrica

El Alcohol O2 cuenta con un conector AMP blindado que contiene los cableados de las sondas, alimentación del acondicionador y salidas analógicas.

### 5.1 Conexiones del arnés eléctrico

Color del cable	Pin	Conexión	Observación
Azul	3	Sonda 2	H+ de la sonda 2
Amarillo	4	Sonda 2	H- de la sonda 2
Blanco	5	Sonda 2	IP+ de la sonda 2
Negro y Blanco	8 y 9	Chasis del vehículo	Conectar al bloque, tapa de cilindros o chasis del vehículo. <b>No conectar al borne negativo de la batería. No conectar junto al cable negro de este cableado.</b>
Gris	10	Sonda 2	VS+ de la sonda 2
Marrón	11	Sonda 2	VS- de la sonda 2

Color del cable	Pin	Conexión	Observación
Amarillo/rojo	12	Salida analógica	Salida analógica 0-5V del señal de la sonda 2
Blanco/ rojo	13	CAN FT	CAN HI para comunicación con FT500
Negro	14 y 15	Negativo de la batería	Conectar directamente al negativo de la batería del vehículo <b>Conectar directo al borne negativo de la batería. No conectar junto al cable negro/blanco de este cableado.</b>
Gris	16	Sonda 1	VS+ de la sonda 1
Marrón	17	Sonda 1	VS- de la sonda 1
Amarillo/ rojo	18	Salida analógica	Salida analógica 0-5V do señal da sonda 1
Amarillo/ Azul	19	CAN FT	CAN LOW para comunicación con la FT500
Rojo	20	Positivo post-llave (12V)	Se recomienda la utilización de un fusible de 15A
Azul	22	Sonda 1	H+ de la sonda 1
Amarillo	23	Sonda 1	H- de la sonda 1
Branco	24	Sonda 1	IP+ de la sonda 1

ES

### 5.2 Esquema de conexión del conector eléctrico

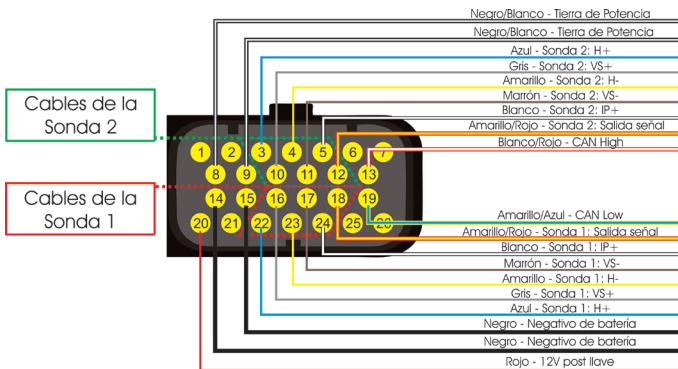

### 5.3 Calibración al aire libre (free-air)

Para la utilización del Alcohol O2 es obligatoria la calibración de los sensores al aire libre. Para realizar la calibración, es necesario remover la sonda del escape y dejar ventilando por 10 minutos, conectar el Alcohol O2 en la línea Power FT. Después de calentadas las sondas, espere más 3 minutos y va a través de la interface hasta Menú Principal/Sensores y Calibración/Sonda (1 o 2) / Alcohol O2 y presione calibrar.



La calibración también puede ser realizada a través del FT Manager, a través de la siguiente pantalla:

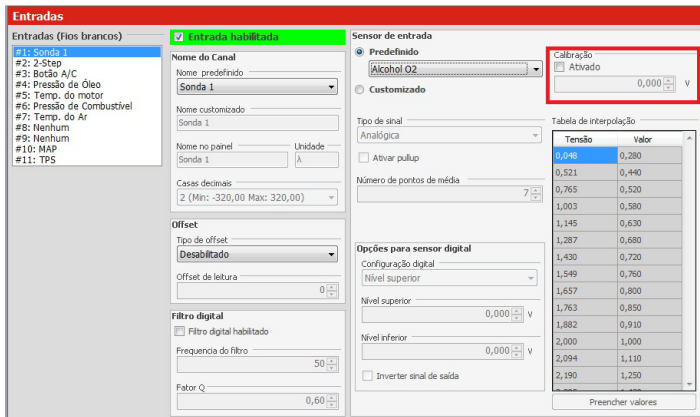

El voltaje de la salida analógica para aire libre en sensores NTK es de 3.000V. Para sensores Bosch é 2,700V.

Mientras los sensores están calentando, el voltaje de la salida analógica del Alcohol O2 debe quedar en 5.000V.

Cualquier diferencia mayor do que 0.100V durante el calentamiento debe ser checada, pues puede indicar calibración incorrecta, sensor dañado o problemas en la instalación eléctrica, principalmente en los cables negativo (negro) y tierra de potencia (negro y blanco).

ES

5.4 Tabla de lambda/AFR x voltaje de la salida analógica

Voltaje (V)	AFR (Gasolina)	AFR (Alcohol)	Lambda
0.048	4.120	1.800	0,280
0.521	6.470	2.820	0,440
0.765	7.640	3.340	0,520
1.003	8.530	3.720	0,580
1.145	9.260	4.040	0,630
1.287	10.000	4.370	0,680
1.430	10.580	4.620	0,720
1.549	11.170	4.880	0,760
1.657	11.760	5.140	0,800
1.763	12.500	5.460	0,850
1.882	13.380	5.840	0,910
2.000	14.700	6.420	1,000
2.094	16.320	7.130	1,110
2.190	18.380	8.030	1,250
2.285	21.020	9.180	1,430
2.380	24.400	10.660	1,660
2.427	26.460	11.560	1,800
2.475	28.960	12.650	1,970
2.523	32.050	14.000	2,180
2.569	35.720	15.600	2,430
2.617	40.430	17.660	2,750
2.665	46.310	20.220	3,150
2.711	53.950	23.560	3,670
2.736	59.240	25.870	4,030
2.760	65.420	28.570	4,450
2.783	72.770	31.780	4,950
2.808	82.320	35.950	5,600
2.854	110.250	48.150	7,500
2.902	167.870	73.320	11,420
2.973	343.250	149.910	23,350
3.006	470.400	205.440	32,000

ES

Notas

---

---

---

---

---

---

---

---

---

---

---

---

---

---

---

---

---

---

---

---

---

---

---

---

---

---

---

---

---

---

ES







## **USA**

455 Wilbanks Dr.  
Ball Ground, GA, 30107, USA

Phone: +1 678-493-**FUEL**  
+1 678-493-3835

Toll Free: +1 855-595-**FUEL**  
+1 855-595-3835

E-mail: [info@fueltech.net](mailto:info@fueltech.net)  
[www.FuelTech.net](http://www.FuelTech.net)

## **Brasil**

Av. Bahia, 1248, São Geraldo  
Porto Alegre, RS, Brasil, CEP 90240-552

Fone: +55 (51) 3019 0500  
SAC: 82\*6009  
Comercial: 82\*109584

E-mail: [info@fueltech.com.br](mailto:info@fueltech.com.br)  
[www.FuelTech.com.br](http://www.FuelTech.com.br)