



LTC - NTK LAMBDA TO CAN



MoTeC's LTC NTK (Lambda to CAN module) monitors, controls and diagnoses an NTK Lambda sensor, and transmits Lambda readings on a CAN bus. When using LTC NTKs, up to 32 Lambda sensors can be configured on a single CAN bus allowing an ECU or logging device to simultaneously monitor multiple Lambda sensors.

► FEATURES

- Provides accurate Lambda measurement even when exhaust gas temperature is changing rapidly (heating or cooling).
- Calibrated by the user for a particular sensor using either the initial sensor factory calibration, the free air calibration, or (for NTK sensors only) the referenced gas calibration.
- Pre-configured to suit a single unit installation. If necessary, the configuration can be adjusted; see the Configuration section for more details.

► COMPATIBILITY

MoTeC ECU Models

- M84, M400, M600, M800, M880, M1 Series

MoTeC Dash/Logger Models

- ACL, SDL*, SDL3, ADL*, ADL2*, ADL3, CDL3, C125, C185, C127, C187 — *product is discontinued

► PC COMMUNICATIONS

A MoTeC gateway device is required to communicate with the LTC on CAN. These are:

- M1 Series ECUs
- ACL, ADL3, SDL3, CDL3, all C Series display loggers
- UTC (USB to CAN) #61059

► SPECIFICATIONS

Inputs/Outputs

- 1 x NTK Lambda sensor (MoTeC #57007)
- Power supply voltage 11 V - 16 V
- Power supply current 110 mA typical plus the sensor heater current. Heater current is typically 0.5 A - 1 A and up to 2 A on startup.

Communications

- 1 x CAN — using LTC Manager, configurable to: 125Kbps, 250Kbps, 500Kbps or 1Mbps

Physical

- Dimensions: 38 x 26 x 14 mm, excluding wiring looms and connectors
- Weight: 62 g
- 1 x 4 pin male DTM connector (power/CAN)
- 1 x mating connector for NTK Lambda sensor
- Maximum ambient temperature: 100 °C

► SOFTWARE

For multiple installations, LTC Manager software allows all units to be simultaneously managed and diagnosed.

The software is used to:

- Configure and calibrate all units on the CAN bus
- Display readings and diagnostics
- Configure CAN transmission addresses
- Control free air sensor calibration
- Update unit firmware.

► **CONFIGURATION**

MoTeC LTCs come pre-configured to suit a single LTC unit installation. By default, the initial factory sensor calibration is used and CAN address 460.

It is only necessary to use LTC Manager if installing multiple LTC units, or if changes to the default settings are required.

► **DIMENSIONS AND MOUNTING**

All dimensions in mm.

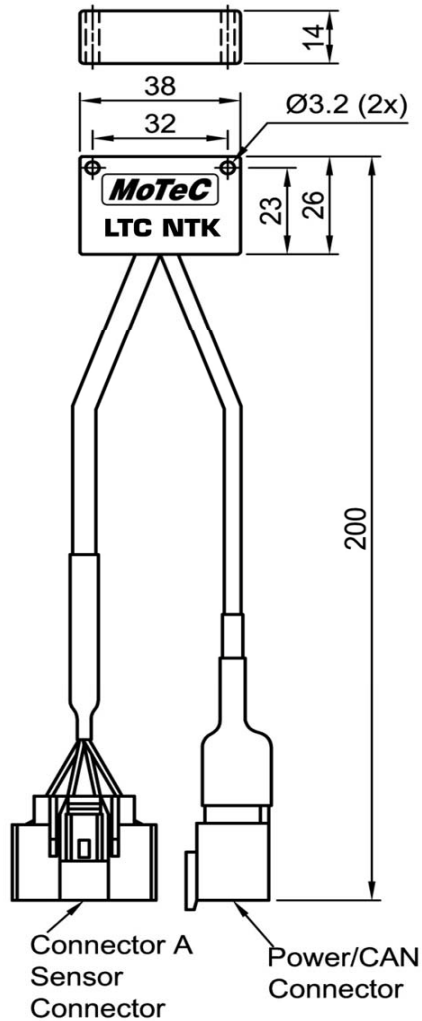

► **CONNECTOR PINOUTS**

Connector A (and B for dual version)

NTK sensor connector

Mating connector: supplied on sensor

Pin	Wire Colour	Description
1	Blue	Heater +
2	Yellow	Heater -
3	Orange	Rc
4	Black	Sensor 0 V
5	Not connected	
6	Grey	Vs
7	White	Ip
8	Black	Sensor 0 V

Power / CAN Connector

DTM 4pin (M) (#68055)

Mating connector: DTM 4pin (F) #68054

Pin	Wire Colour	Description
1	Black	Battery -
2	Green	CAN Lo
3	White	CAN Hi
4	Red	Battery +

► **WIRING**

To power the LTC, connect either to the ignition switch for fast sensor start up or connect to the fuel pump relay to prevent accidental battery drainage.

Wiring example

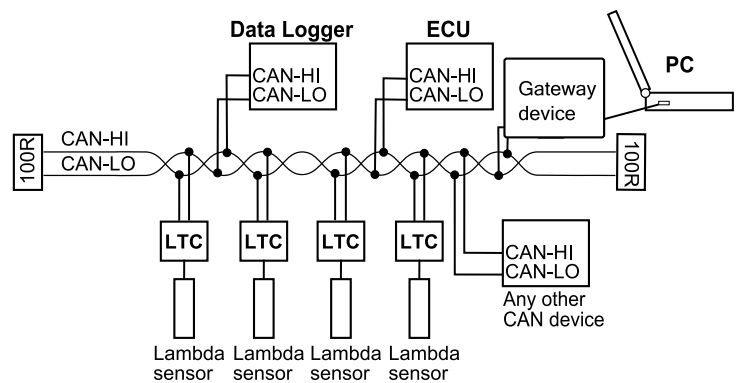

For information on wiring a CAN bus with several LTCs and any number of other CAN devices (as in the example), refer to the relevant device manual.